

EDGETEQ

S-356

EDGETEQ S-356
EDGETEQ S-356 TWO COLOR
EDGETEQ S-356 TWO COLOR NARROW
EDGETEQ S-356 TWO COLOR With V-belt

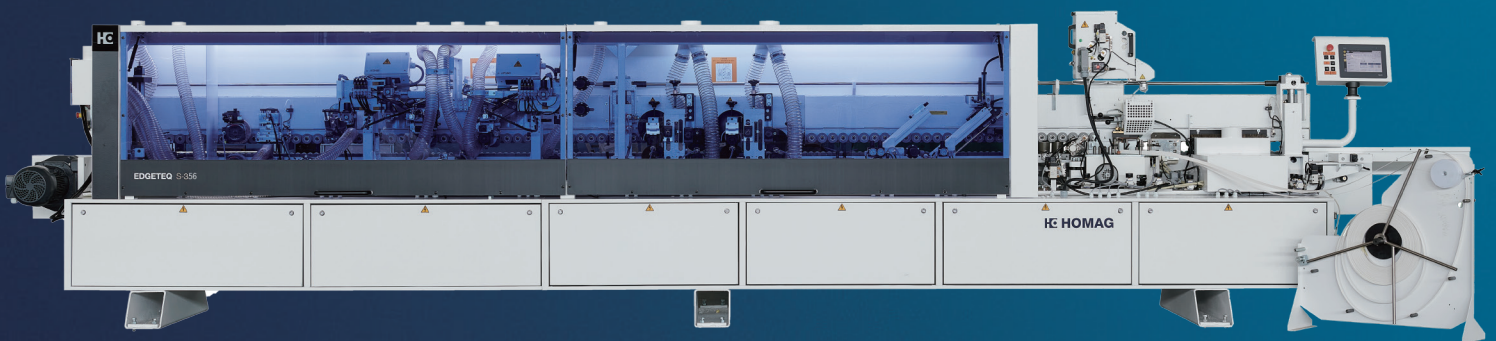

EDGETEQ S-356 entry into the industrial class

The EDGETEQ S-356 offers complete processing due to its comprehensive equipment. The powerful motors on all units provide the unrestricted power which is needed to process a broad spectrum of different parts. Whereas the joint trimming unit guarantees the ideal formatting of the panel, the quick melt gluing unit guarantees the optimal edge banding. The snipping unit is equipped with 2 motors and offers a highly precise cut.

High performance of the trimming units are rounding off the picture. The 4-motor profile trimming unit enjoys all the advantages of an entire processing, being supported by the profile scraping unit, the glue joint scraping unit and the buffing unit, making the finish absolutely perfect.

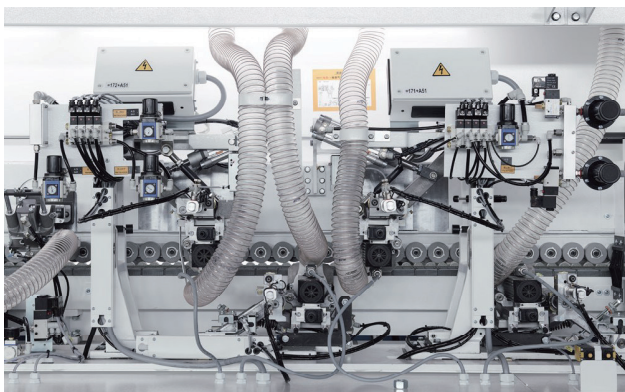
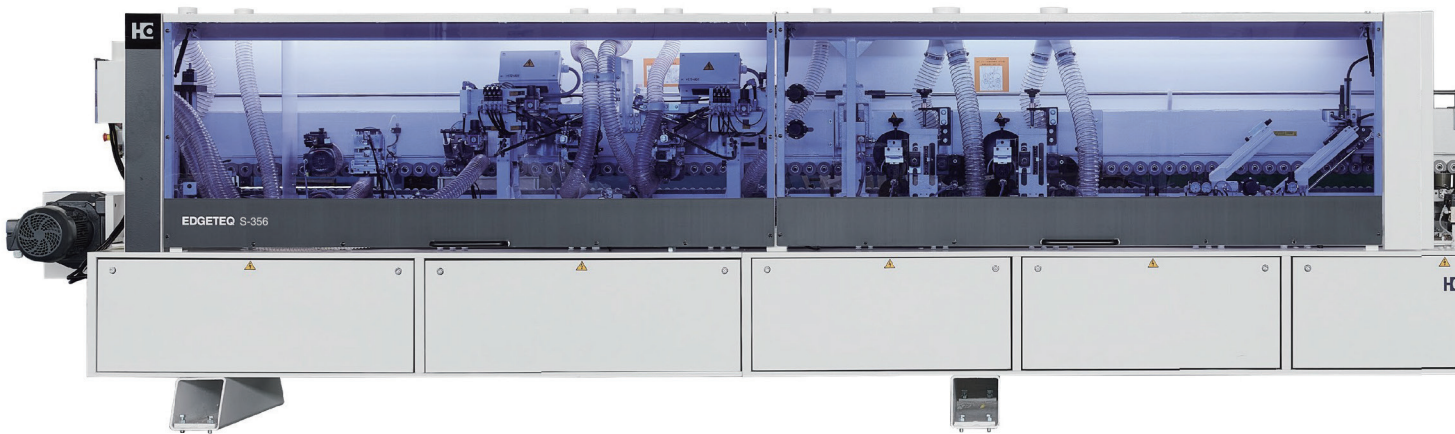

Profile trimming unit: For profile trimming of thick PVC edges. Workpiece thickness up to 60 mm. Standard pneumatic on/off. For easy operating. Max. feed speed 25 m/min.

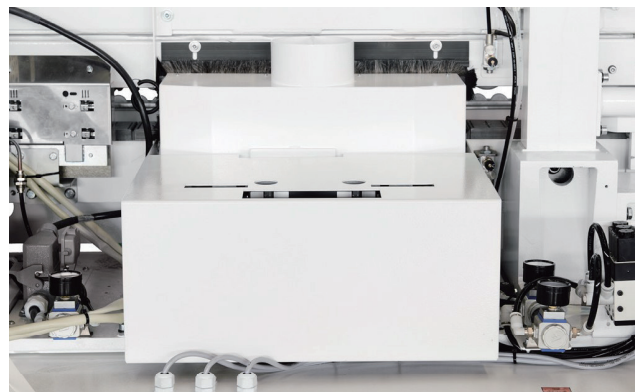

Joint trimming unit: Perfect cut and long service life due to diamond tipped tools for optimum edge joint quality.

Series EDGETEQ S-356 – the highly flexible all-rounder.

- HOMAG gluing system high quality gluing from top to down, fresh glue and accurate gluing temperature.
- Snipping unit more stable and strong structure with double guiders and reliability.
- Fine trimming unit more stable, keep high product quality.
- Corner rounding unit more stable and high quality, 4 motors design, easy adjustment and high speed up to 25 m/min.



EDGETEQ S-356

Machine length	8, 499
Weight (kg)	4, 200
Feed speed (m/min)	16 - 25
Edge thickness (mm)	0.4 - 3
Workpiece thickness (mm)	12 - 60

YOUR BENEFITS AT A GLANCE

- Optimum glue application on the narrow surface.
- Changes to workpiece thicknesses do not necessitate resetting of the glue application roller.
- Glue roller with integrated heating guarantees constant temperature and viscosity for all workpiece thicknesses.
- Tracing pad prevents wear of the application roller and ensures a consistent glue film thickness.
- Easy removal of the application unit.

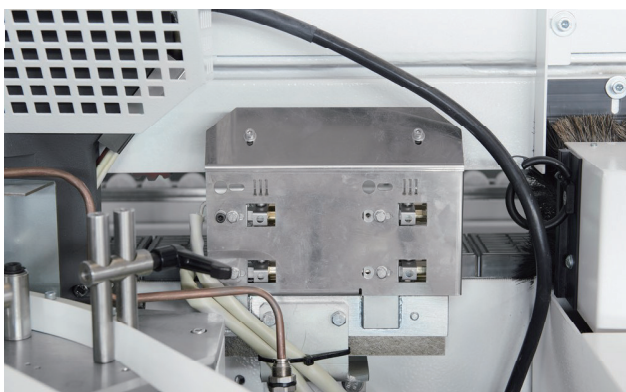

Radiant heater: Strong adhesion through optimal pre heating of the workpiece.

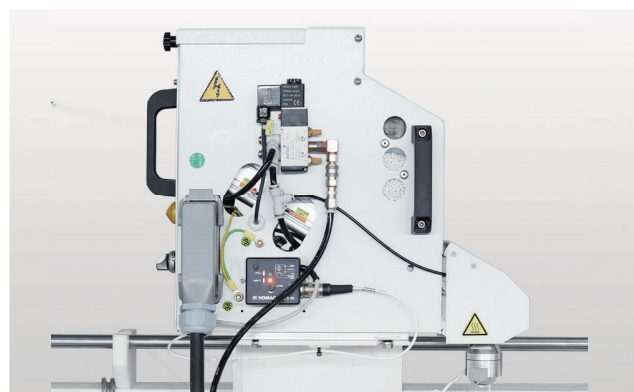

Gluing unit and pre-melter: Quick-change application unit with hot melt glue supply from top. On-demand availability and perfect glue quality with Quickmelt.

EDGETEQ S-356: TWO COLOR

The EDGETEQ S-356 offers complete processing due to its comprehensive equipment. The powerful motors on all units provide the unrestricted power which is needed to process a broad spectrum of different parts. Whereas the joint trimming unit guarantees the ideal formatting of the panel, the quick melt gluing unit guarantees the optimal edge banding. The snipping unit is equipped with 2 motors and offers a highly precise cut.

High performance of the trimming units are rounding off the picture. The 4-motor profile trimming unit enjoys all the advantages of an entire processing, being supported by the profile scraping unit, the glue joint scraping unit and the buffing unit, making the finish absolutely perfect.

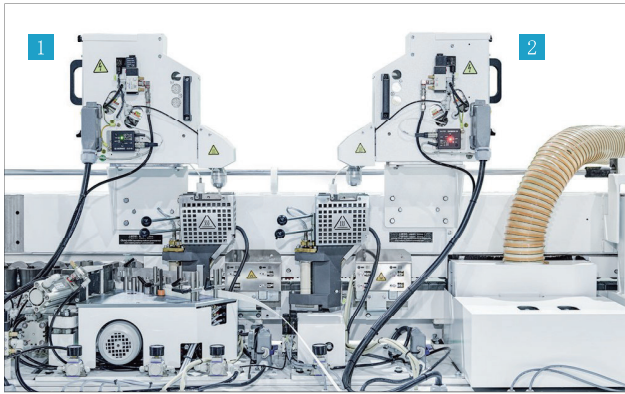

Gluing unit and pre-melter: Quick-change application unit with hot melt glue supply from top. On-demand availability and perfect glue quality with Quickmelt. (1 # optional PUR coating)

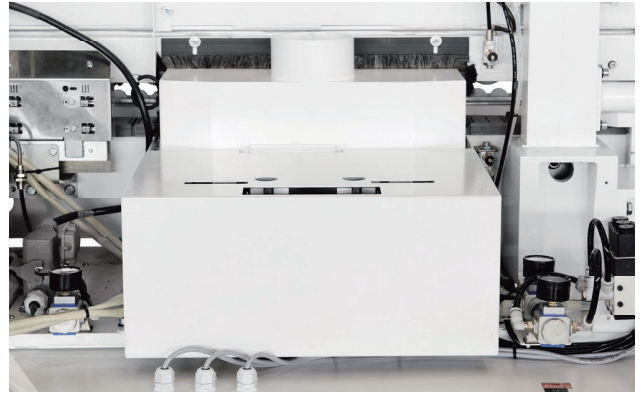

Joint trimming unit: Perfect cut and long service life due to diamond tipped tools for optimum edge joint quality.

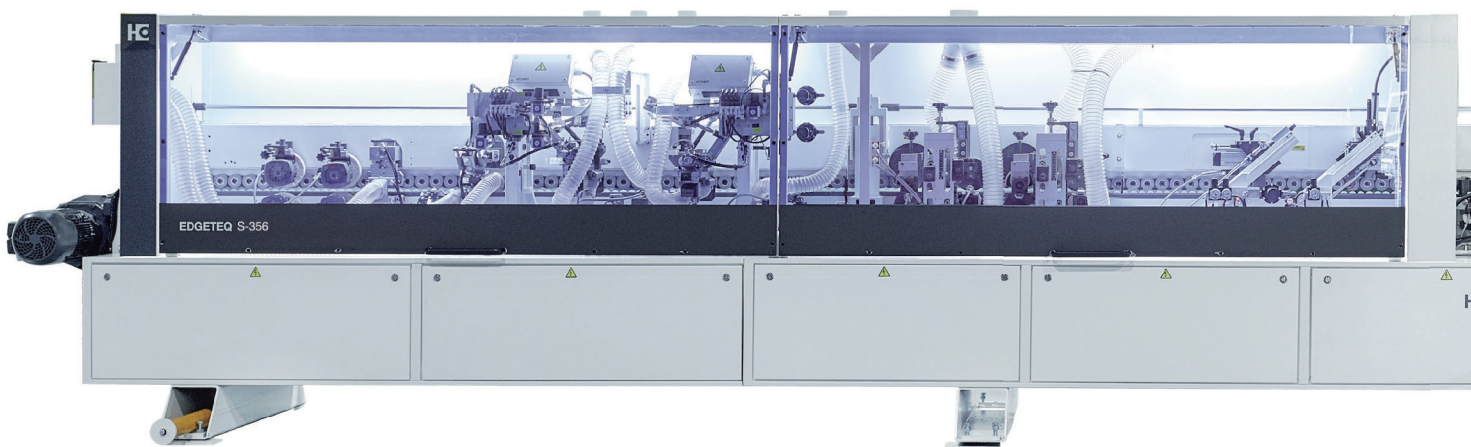

Series EDGETEQ S-356 TWO COLOR
the highly flexible all-rounder.

- HOMAG gluing system high quality gluing from top to down, fresh glue and accurate gluing temperature.
- Snipping unit more stable and strong structure with double guiders and reliability.
- Fine trimming unit more stable, keep high product quality.
- Corner rounding unit more stable and high quality, 4 motors design, easy adjustment and high speed up to 25 m/min.
- Can meet the switching use of EVA adhesive with different colors (or EVA+PUR)

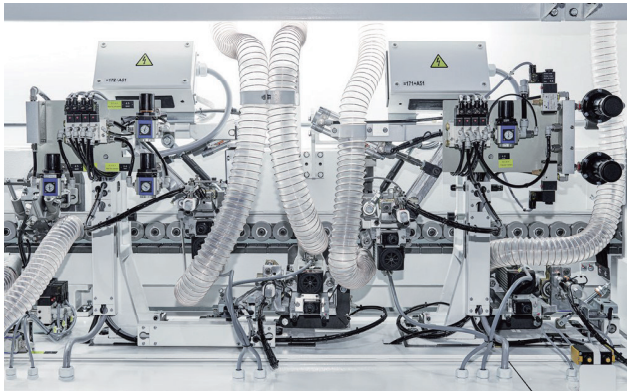

Profile trimming unit: For profile trimming of thick PVC edges. Workpiece thickness up to 60 mm. Standard pneumatic on/off. For easy operating. Max. feed speed 25 m/min.

EDGETEQ S-356 TWO COLOR

Machine length (mm)	8, 939
Weight (kg)	4, 400
Feed speed (m/min)	16 - 25
Edge thickness (mm)	0.4 - 3
Workpiece thickness (mm)	12 - 60

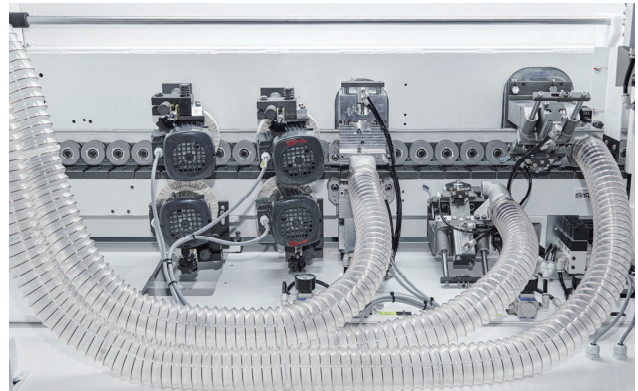

Double polishing device: Meets the coating requirements of two different colors and improves the surface appearance quality. Standard 1 pic polishing device.

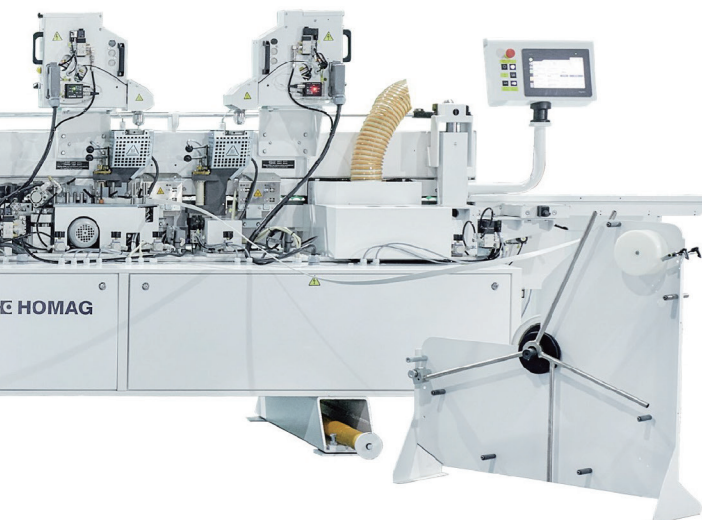

YOUR BENEFITS AT A GLANCE

- Optimum glue application on the narrow surface.
- Changes to workpiece thicknesses do not necessitate resetting of the glue application roller.
- Glue roller with integrated heating guarantees constant temperature and viscosity for all workpiece thicknesses.
- Tracing pad prevents wear of the application roller and ensures a consistent glue film thickness.
- Easy removal of the application unit.

EDGETEQ S-356: TWO COLOR NARROW

The EDGETEQ S-356 offers complete processing due to its comprehensive equipment. The powerful motors on all units provide the unrestricted power which is needed to process a broad spectrum of different parts. Whereas the joint trimming unit guarantees the ideal formatting of the panel, the quick melt gluing unit guarantees the optimal edge banding. The snipping unit is equipped with 2 motors and offers a highly precise cut.

High performance of the trimming units are rounding off the picture. The 4-motor profile trimming unit enjoys all the advantages of an entire processing, being supported by the profile scraping unit, the glue joint scraping unit and the buffing unit, making the finish absolutely perfect.



Infeed device: For narrow parts infeed in crosswise.

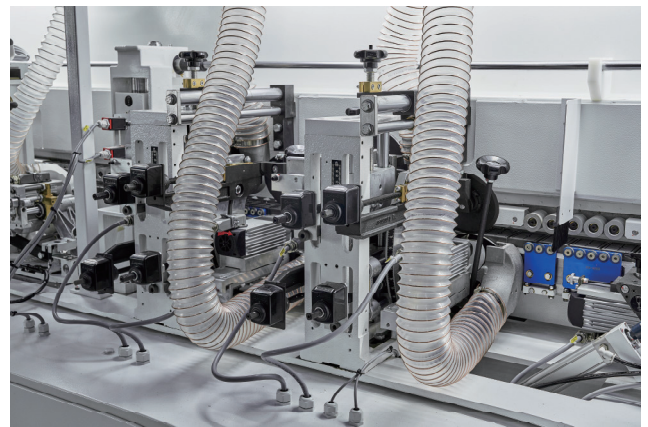

Fine trimming unit: Process overhang edge from top and bottom (rough trimming unit as option).

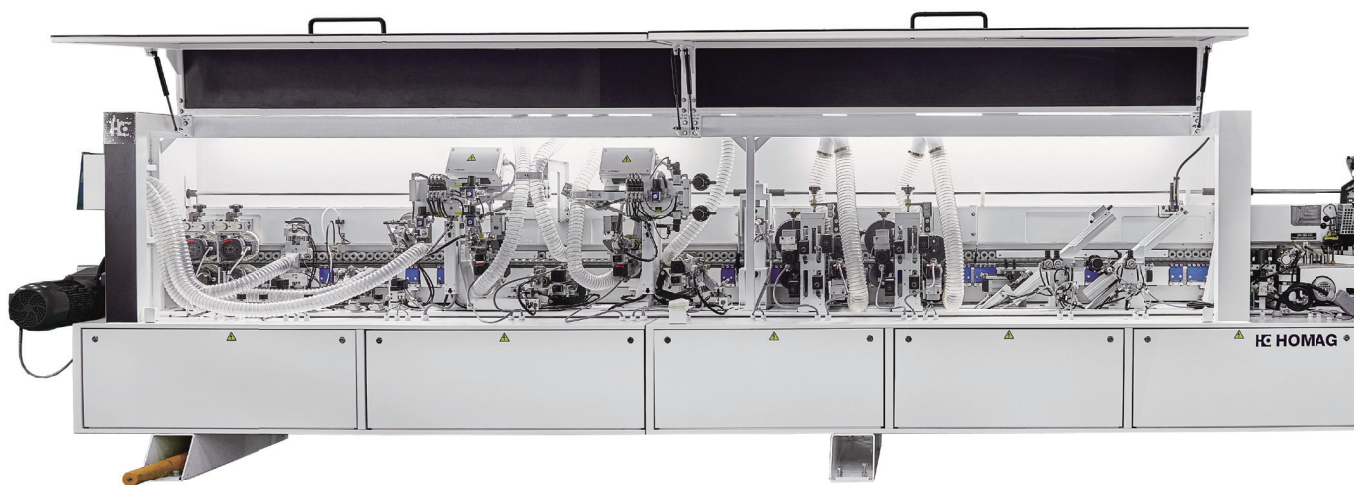

Series EDGETEQ S-356 TWO COLOR NARROW
the highly flexible all-rounder.

- HOMAG gluing system high quality gluing from top to down, fresh glue and accurate gluing temperature.
- Snipping unit more stable and strong structure with double guiders and reliability.
- Fine trimming unit more stable, keep high product quality.
- Corner rounding unit more stable and high quality, 4 motors design, easy adjustment and high speed up to 25 m/min.
- Can meet the switching use of EVA adhesive with different colors (or EVA+PUR).
- Infeed device, help to infeed narrow parts.
- Auxiliary pressure rollers design for narrow parts with patent, make sure narrow parts processing stable.
- Auxiliary pressure rollers adjust individually.
- Fast-response sensor for line control, measure workpieces size and position, increase process accuracy.

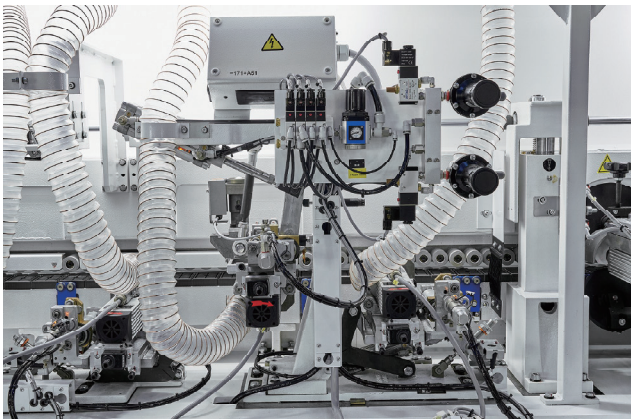

Profile trimming unit: For profile trimming of thick PVC edges. Workpiece thickness up to 60 mm. Standard pneumatic on/off. For easy operating. Max. feed speed 25 m/min.

EDGETEQ S-356 TWO COLOR NARROW	
Machine length (mm)	8, 939
Weight (kg)	4, 400
Feed speed (m/min)	16 - 25
Edge thickness (mm)	0.4 - 3
Workpiece thickness (mm)	12 - 60
Minimum workpiece width (mm)	40

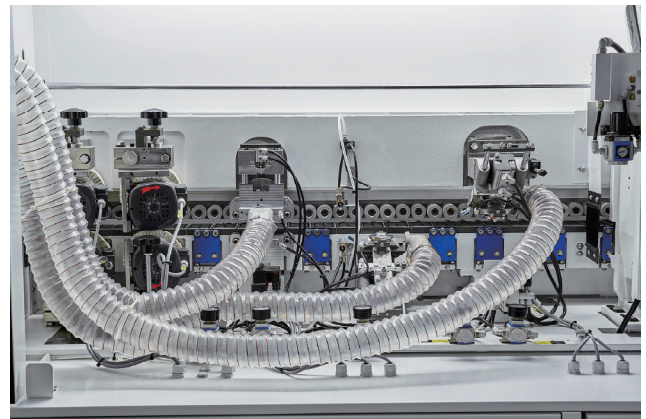

Double polishing device: Meets the coating requirements of two different colors and improves the surface appearance quality. Standard 1 pic polishing device.

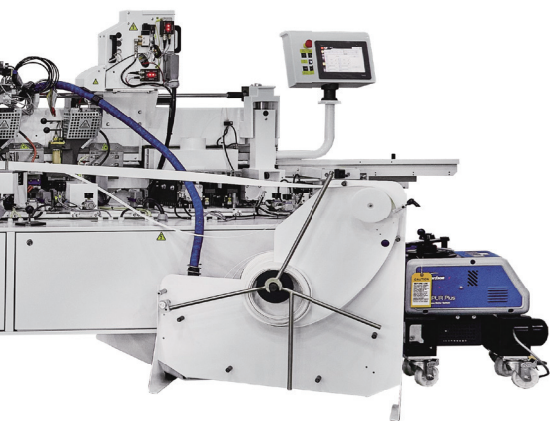

YOUR BENEFITS AT A GLANCE

- Optimum glue application on the narrow surface.
- Changes to workpiece thicknesses do not necessitate resetting of the glue application roller.
- Glue roller with integrated heating guarantees constant temperature and viscosity for all workpiece thicknesses.
- Tracing pad prevents wear of the application roller and ensures a consistent glue film thickness.
- Easy removal of the application unit.

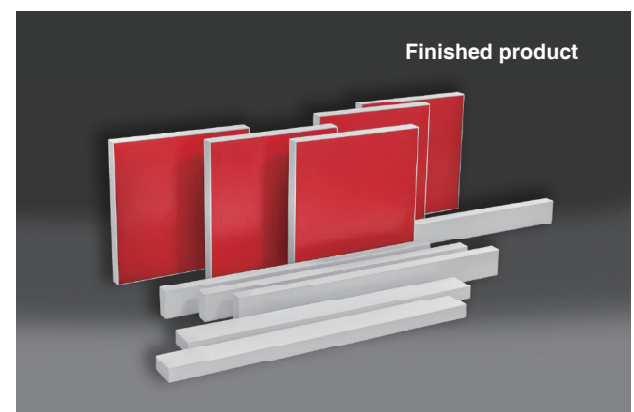

EDGETEQ S-356 TWO COLOR With V-belt

The EDGETEQ S-356 offers complete processing due to its comprehensive equipment. The powerful motors on all units provide the unrestricted power which is needed to process a broad spectrum of different parts. Whereas the joint trimming unit guarantees the ideal formatting of the panel, the quick melt gluing unit guarantees the optimal edge banding. The snipping unit is equipped with 2 motors and offers a highly precise cut.

High performance of the trimming units are rounding off the picture. The 4-motor profile trimming unit enjoys all the advantages of an entire processing, being supported by the profile scraping unit, the glue joint scraping unit and the buffing unit, making the finish absolutely perfect.



The steel upper pressure beam and V-belt are tightly pressed to ensure smooth delivery of the workpiece

- The upper pressure beam is made of thickened steel
- Double V upper compression conveyor belt



Controller - Easy to operate: The touch screen interface ensures quick integration and comfortable operation of the menu bar

- 15 inch large touch screen
- Rotatable angle

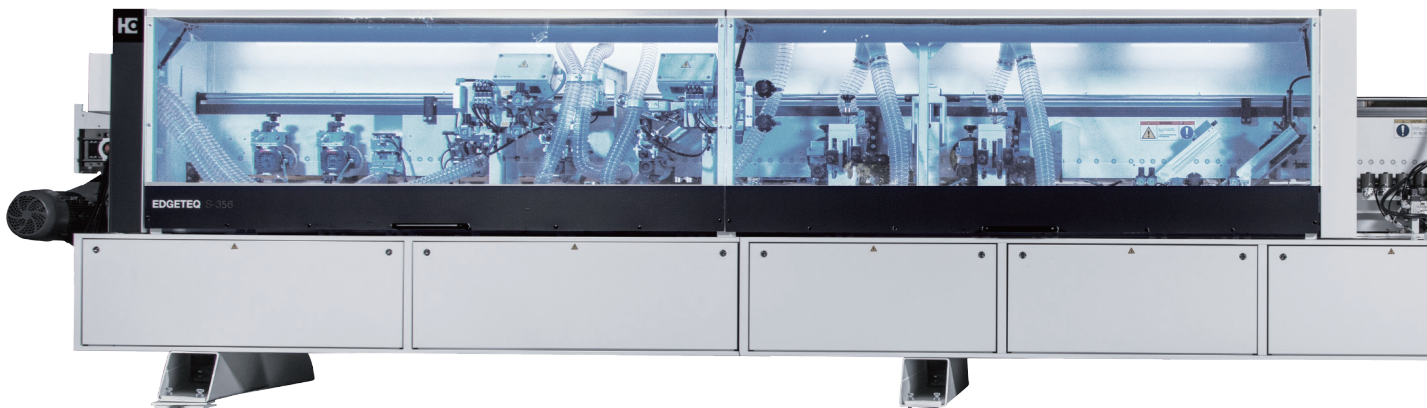

**Series EDGETEQ S-356 TWO COLOR With V-belt
the highly flexible all-rounder.**

- HOMAG gluing system high quality gluing from top to down, fresh glue and accurate gluing temperature.
- Snipping unit more stable and strong structure with double guiders and reliability.
- Fine trimming unit more stable, keep high product quality.
- Corner rounding unit more stable and high quality, 4 motors design, easy adjustment and high speed up to 25 m/min.
- Can meet the switching use of EVA adhesive with different colors (or EVA+PUR)

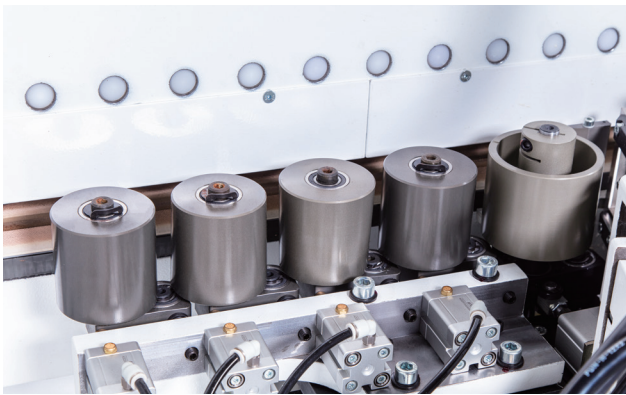

Pressure wheel group

- 1 main pressure wheel with power, diameter 86 mm
- 4 auxiliary pressure rollers, diameter 70 mm, 2 with taper
- Pneumatic compression and adjustment

EDGETEQ S-356 TWO COLOR With V-belt

Machine length (mm)	8, 939
Weight (kg)	4, 400
Feed speed (m/min)	16 - 25
Edge thickness (mm)	0.4 - 3
Workpiece thickness (mm)	12 - 60

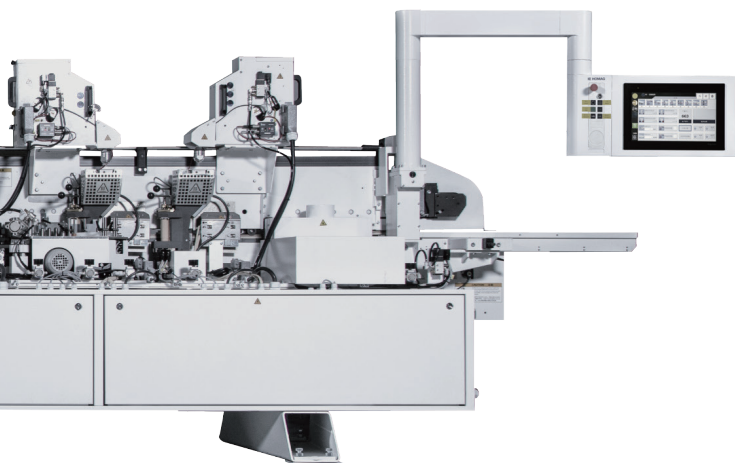

HC LIFE CYCLE SERVICES

The sale of our machines comes with all-in optimum service backup and individual advice. We support you with service innovations and products which are especially tailored to your requirements. With short response times and fast

customer solutions we guarantee consistently high availability and economical production – over the entire life cycle of your machine.



REMOTE SERVICE

- Hotline support via remote diagnosis by our trained experts regarding control, mechanics and process technology. Thus, more than 90% less on-site service required and consequently a faster solution for you!
- The ServiceBoard App helps to solve tasks in a fast, simple and concrete way. This is achieved by mobile live video diagnosis, automatic sending of service requests or the online spare parts catalog eParts.

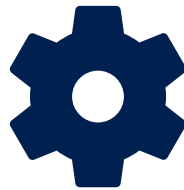

SPARE PARTS SERVICE

- High spare parts availability and fast delivery.
- Ensuring quality by predefined spare parts and wear parts kits, comprising original spare parts.
- Identify and inquire for spare parts online under www.eParts.de 24/7, or buy even faster and more comfortably in the new HOMAG Webshop eCommerce.



MODERNIZATION

- Keep your machinery up to date and increase your productivity as well as your product quality, This is how you can meet tomorrow's requirements today!
- We support you with upgrades, modernization as well as individual consultancy and developments.



DIGITAL SERVICES

- ISN (intelliServiceNet) – The new remote service solution of the future! Fast restart of production because the remote service employee has extensive access to relevant physical data.
- intelliAdvice App – provides help for self-help. The preventive solutions proposed in the new App are the combination of our experiences and existing machine data.



SOFTWARE

- Telephone support and consultancy through software support.
- Digitalization of your spare parts via 3D scanning saves time and money compared to new programming.
- Subsequent networking of your machinery with intelligent software solutions ranging from construction to production.



FIELD SERVICE

- Increased machine availability and product quality by certified service staff.
- Regular checks through maintenance / inspection guarantee the highest quality of your products.
- We offer you the highest availability of technicians in order to reduce downtimes in case of unpredictable troubles.

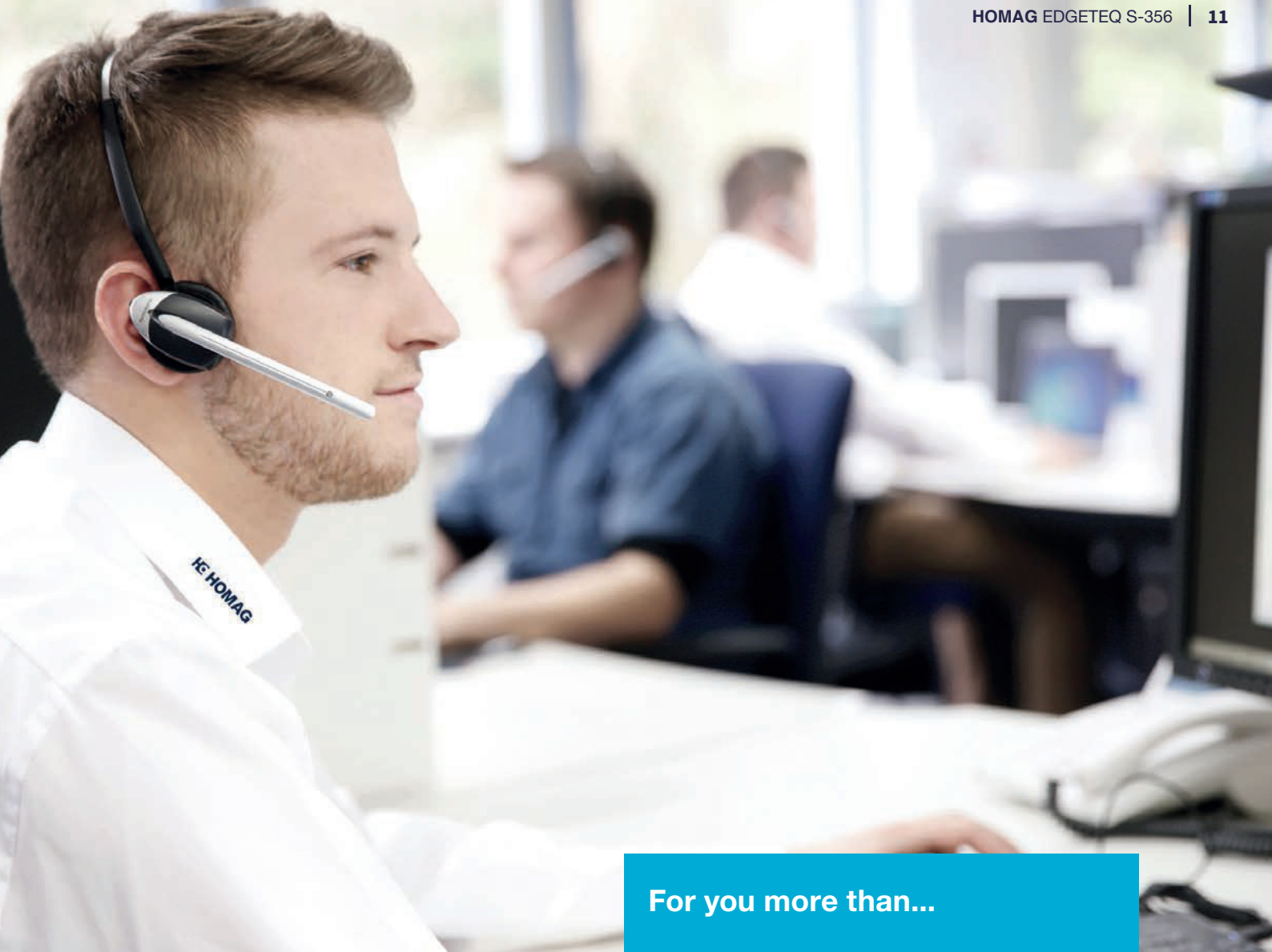

TRAINING

- . Thanks to training perfectly suited to your requirements, your machine operators can optimally operate and maintain the HOMAG machines.
- . The training also include customer-specific training documents with exercises proven in practice.
- . Online training and webinars. Learn without traveling, meet your trainer in the digital classroom.

For you more than...

1,350

service employees worldwide

90 %

less on-site service thanks to successful remote diagnosis

5,000

customer training sessions per / year

150,000

machines, all electronically documented in 28 different languages – in eParts



HOMAG Group AG

marketing-chn@homag.com

www.homag.com

For more details, please scan
the QR code to follow Homag China



WeChat
homag_china



HOMAG
Mini program

YOUR SOLUTION